



Product brochure

Cyberex[®] PowerBuilt[™] Industrial UPS

Uninterruptible power supply system

Single phase 10–80kVA

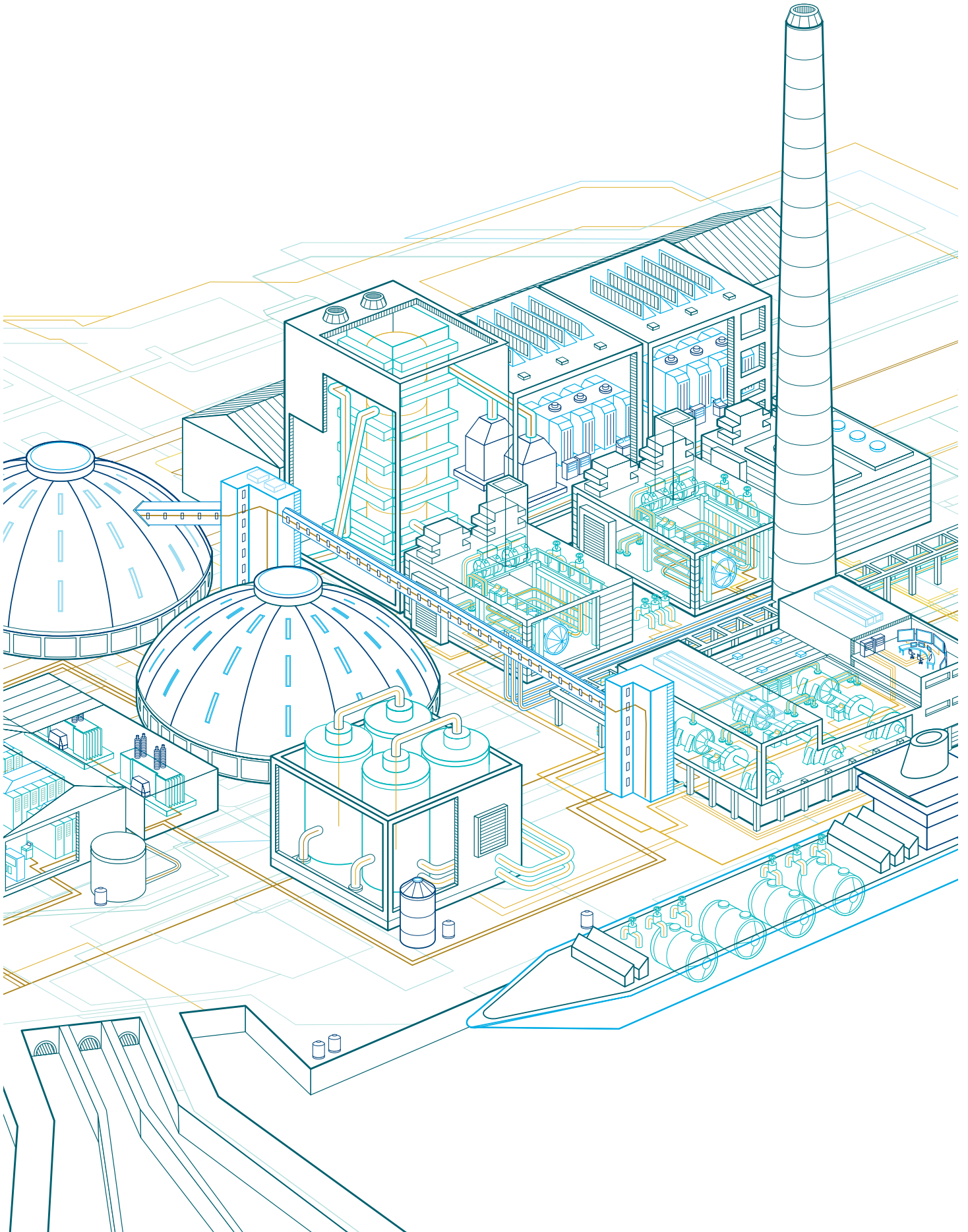

Cyberex® PowerBuilt™ Industrial UPS – single phase

Power quality detection in the Cyberex® PowerBuilt™

The Cyberex® PowerBuilt™ is a true online double-conversion industrial UPS designed to support the continuing demand from downstream refining and petrochemicals, upstream oil and gas, power generation, and the growing regulatory and safety needs of today's industrial complexes. The PowerBuilt™ Series UPS is designed to UL 1778 safety and IEC 62040-3 performance standards; and therefore, it can be scaled to meet changing electrical requirements and is adaptable to the most stringent technical specification.

The newly developed intelligent control logic internal to the PowerBuilt™ industrial UPS is the silent sentry that continuously safeguards the system to ensure uninterrupted operation. It is equipped with an unmatched user interface with full-color touch screen GUI for self-guided, serviceability with minimal engagement, and the latest communication protocols. It also features a patented digital static transfer switch design, which enhances system performance through increased redundancy and reliability. The fully rated switch provides better protection of critical loads from input power transients and interruptions by eliminating any single point of failure.

The conventional zero-crossing methods used for fault detection require multiple measuring periods that must be computed over phase noise. The PowerBuilt™ UPS phase-locked loops (PLL) control system is a proprietary correlation method that enables precise measurements of an input/output waveform, resulting in shorter measurement periods and rapid reaction to protect the critical load during a power quality event.

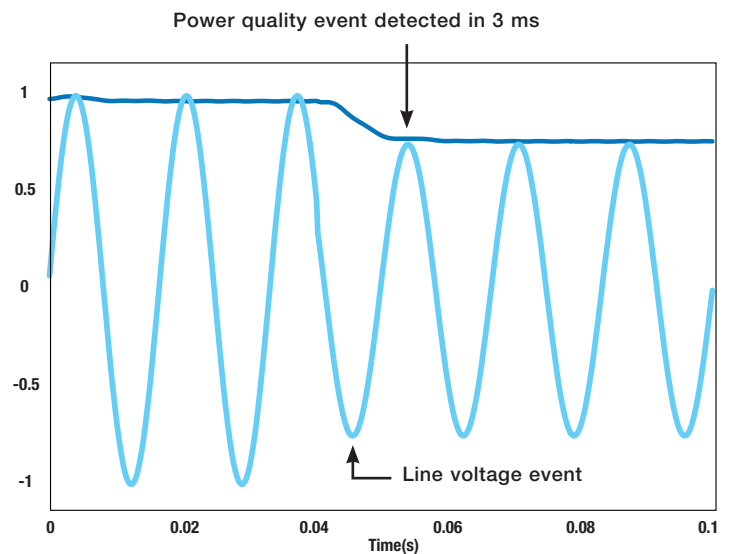

Figure 1: System reacting to a power quality event

UL and IEC compliant



High overload capacity on inverter

The threat of lost production or the possibility of damage to work in process is a central manufacturing concern. The Cyberex® PowerBuilt™ industrial UPS features an innovative IGBT based pulse-width modulation (PWM) inverter design that employs active current limitation for higher short circuit tolerance. The active short-circuit method ensures the best possible current clearing waveform, while still protecting the inverter from catastrophic failure. In the event of a load side short circuit or over-current that cannot be supplied by the inverter, the UPS logic will transfer away from the active inverter source, thereby preventing the fault condition from damaging the inverter.

Hardware configuration

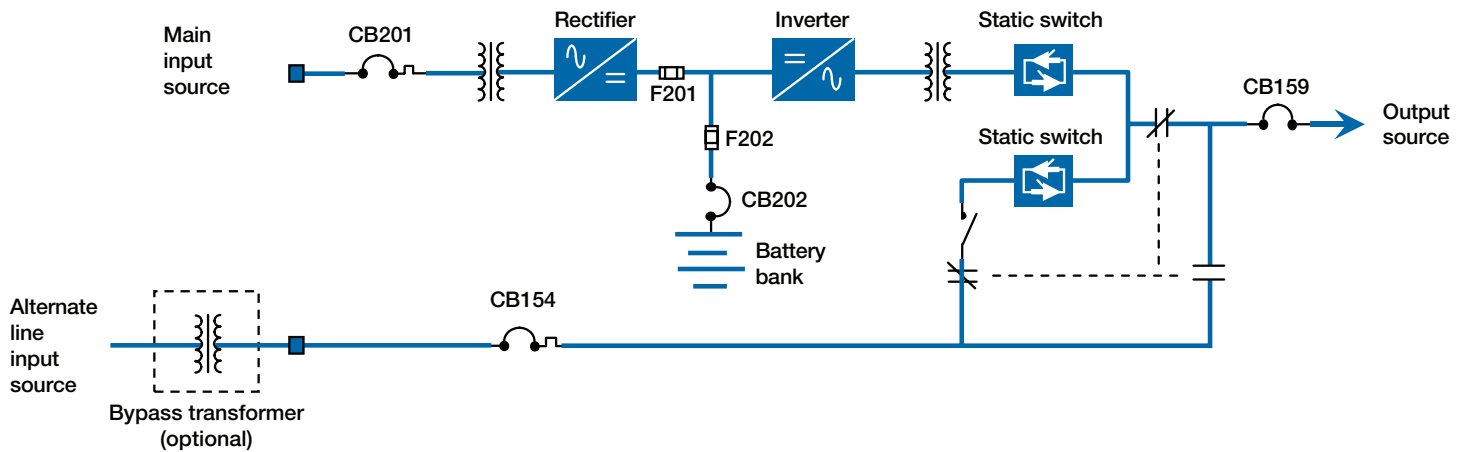

Figure 2: Single line diagram



Standard features

Design

- IGBT-based PWM inverter
- Digital signal processing (DSP) for all control mechanisms
- Full-color touch screen monitor panel, 10.4" VGA TFT LED
- Full isolation – input/output transformers
- Fully rated static switch
- Maintenance bypass switch
- Superior short-circuit detection
- UV shunt trip on battery disconnect
- Alternate source input breaker
- Phase-locked loops for higher reliability
- Redundant design with no single point of failure

Communications

- RS-485 (modbus two/four wire) port. Modbus RTU & ASCII
- USB service port
- EPO input
- TCP (modbus/TCP)

Construction

- Vermin shield
- Wire markers
- Redundant system cooling
- Enclosure powder coating in ANSI 61 gray

Mimic/LED indications

- 1% accuracy digital metering
- Alarm assembly with local LEDs for:
 - On inverter
 - On static bypass
 - On battery
 - MBS normal
 - Check battery
 - Battery undervoltage
 - Battery overvoltage
 - Overload
 - Fan failure
 - Rectifier AC input undervoltage
 - Cabinet overtemperature
 - Alternate AC input
 - Undervoltage
 - Heatsink overtemperature
 - Out of sync
 - Summary alarm
- Breaker position package
- Inverter input DC bus voltmeter
- Battery to ground fault alarm
- Battery not available alarm



Optional features

- Drip shield (only covers exhaust fans)
- Bottom cable entry
- Fungus treatment
- Lexan shield (terminal power)
- IR scanning port
- Stainless steel nameplate with stainless steel screws
- SIS wire
- Seismic bracing
- Blocking diode
- Battery temperature compensation
- Burn-in 12, 24, 72 hour
- Certified test reports
- Custom drawing package with optional CAD and PDF files
- MBS solenoid lock on out-of-sync
- MBS solenoid lock on customer-defined precondition
- Pad lockable MBS
- External maintenance bypass cabinet – freestanding (standard for 40–80kVA UPS systems)
- Analog voltmeter in bypass cabinet
- Analog ammeter in bypass cabinet
- External DC battery fused disconnect or circuit breaker

Mimic display

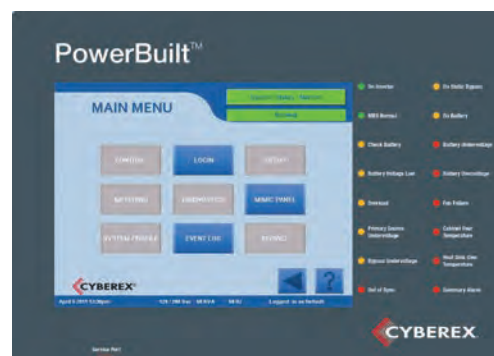

Product specifications

AC input	60Hz
Input voltage	480VAC (3W+G) Consult factory for additional voltages
Max input current @ rated load (nominal VAC)	
(10kVA/8kW)	21A @ 480VAC
(15kVA/12kW)	32A @ 480VAC
(20kVA/16kW)	42A @ 480VAC
(30kVA/24kW)	63A @ 480VAC
(40kVA/32kW)	84A @ 480VAC
(50kVA/40kW)	107A @ 480VAC
(60kVA/48kW)	129A @ 480VAC
(80kVA/64kW)	172A @ 480VAC
Input voltage range	+10, -20%VAC from nominal
Input power factor	0.75 @ full load and nominal
Current walk-in	Up to full load in > 10 seconds
THDi	30–35% typical

DC bus/battery

DC voltage (nominal)	120VDC (60 cells nominal, up to 30kVA) 240VDC (120 cells nominal)
DC range	105–140VDC/210–280VDC
DC regulation	± 1% over full load
DC ripple	± 1% RMS of the DC battery voltage at 100% load with battery connected
DC/AC efficiency	86% (typical)
DC end volts	1.75 V/cell end volts

Environmental

Acoustical noise level	65dBA typical at 3 meters with redundant fans
Operating temperature	0–40°C
Relative humidity	5–95% non-condensing
Enclosure protection	NEMA 1 (IP21)
Access	No rear or side access required for operations or maintenance
AC/AC efficiency	Typical 83% (kW out/kW in)
Cooling	Air cooled with redundant cabinet fans
Heat rejection	
(10kVA/8kW)	7,000 Btu/Hr
(15kVA/12kW)	10,500 Btu/Hr
(20kVA/16kW)	14,000 Btu/Hr
(30kVA/24kW)	21,000 Btu/Hr
(40kVA/32kW)	28,000 Btu/Hr
(50kVA/40kW)	35,000 Btu/Hr
(60kVA/48kW)	42,000 Btu/Hr
(80kVA/64kW)	56,000 Btu/Hr
Operating altitude	Up to 1000 meters w/o derating load
Standard paint	ANSI 61

AC output	60Hz
Output voltages	120V, 2W+G Consult factory for additional voltages
Output current (nominal)	
(10kVA/8kW)	83A @ 120VAC
(15kVA/12kW)	125A @ 120VAC
(20kVA/16kW)	167A @ 120VAC
(30kVA/24kW)	250A @ 120VAC
(40kVA/32kW)	333A @ 120VAC
(50kVA/40kW)	417A @ 480VAC
(60kVA/48kW)	500A @ 480VAC
(80kVA/64kW)	666A @ 480VAC
Voltage regulation	<± 0.5% steady state for 0 to 100% load change
Transient response max.	<± 15% for a 100% load step
Recovery	Return to within ± 1% of nominal within 16 ms
Voltage distortion	Linear loads: <± 2% @100% load Non-linear loads: <± 4% @100% load
Overload	Up to 150% for 10 minutes
Overload static bypass	1000% for 0.1 seconds
Frequency	60Hz
Frequency stability	± 0.01%
Frequency slew rate	Factory set 1Hz/s, user adjustable range: 0.2 – 100Hz/s

Weight

10kVA	120/240V – 1,365 lbs (620 kg)
15kVA	120/240V – 1,650 lbs (749 kg)
20kVA	120/240V – 1,650 lbs (749 kg)
30kVA	120/240V – 1,900 lbs (862 kg)
40kVA	120V – 2,700 lbs (1224 kg) 240V – 2,125 lbs (964 kg)
50kVA	120/240V – 2,900 lbs (1315 kg)
60kVA	120/240V – 3,075 lbs (1394 kg)
80kVA	240V – 3,925 lbs (1780 kg)

Enclosure dimensions

10kVA – 40kVA*	37" (w) x 34.25" (d) x 81.5" (h) (*40kVA high bus only)
40kVA – 80kVA	80" (w) x 38.25" (d) x 81.5" (h)

Safety and acceptance

- UL-1778
- CSA C22.2 no.107.3-05
- Compliant to IEC 62040-2, category 3
- IEC 62040-3 dynamic output classification 1 – sensitive critical loads
- ANSI/NFPA 70 (2014) – conductors

Circuit breakers/fuse sizes ¹					
	Hz	10kVA/8kW	15kVA/12kW	20kVA/16kW	30kVA/24kW
CB 201 – AF/AT²					
480V	60Hz	250AF/30AT	250AF/50AT	250AF/80AT	250AF/80AT
F 202 – Rating (A)					
120VDC	60Hz	150A	250A	300A	500A
240VDC	60Hz	80A	125A	150A	250A
CB 154, 159 – Rating (AF)					
120VAC	60Hz	250A	250A	250A	400A
CB 202 – Rating (AF)					
120VDC	60Hz	250A	250A	250A	400A
240VDC	60Hz	100A	100A	150A	250A

Circuit breakers/fuse sizes ¹					
	Hz	40kVA/32kW	50kVA/40kW	60kVA/48kW	80kVA/64kW
CB 201 – AF/AT²					
480V	60Hz	250AF/150AT	250AF/150AT	250AF/250AT	250AF/250AT
F 202 – Rating (A)					
120VDC	60Hz	600A	800A	800A	–
240VDC	60Hz	300A	400A	500A	600A
CB 154, 159 – Rating (AF)					
120VAC	60Hz	600A	250A	400A	400A
CB 202 – Rating (AF)					
120VDC	60Hz	600A	600A	600A	–
240VDC	60Hz	250A	400A	400A	600A

¹ Reference section 3.1.1 – elements of the system

² AF = breaker frame rating AT = breaker trip rating

Services

A well-maintained power protection system will ensure the integrity and availability of power to critical installations, 24 hours a day, week after week, year after year without fail. ABB offers the most comprehensive and cost-effective service available – ensuring the UPS and other complementary products of your power protection system are expertly maintained on a regular basis and are always ready and able to support your critical business load. From initial contact, through installation, commissioning and maintenance to disposal, ABB provides its customers with an unrivalled single source for all their power protection service needs.



Contact us

Power Protection

5900 Eastport Boulevard
Richmond, VA 23231-4453 USA
Tel: +1 800 292 3739
Fax: +1 804 236 4047

www.abb.com/ups
ric.sales@us.abb.com

We reserve the right to make technical changes to the product and to the information in this document without notice. The agreed conditions at the time of the order shall apply. ABB assumes no responsibility for any errors or omissions that may appear in this document. We reserve all rights in this document and in the information contained therein. Without prior written approval from ABB, reproduction, disclosure to third parties or use of any information, in whole or in part, is strictly forbidden.

© Copyright 2016 ABB, all rights reserved.

051816